

# 2003 GM Cab to Body Interface

Factory Power Locks as Trigger / Interface with Keyless Entry

## TYPICAL RELAY DRIVEN CAB & DOOR SECTION

Late model GM requires a data interface module to add keyless entry Part # 456G.

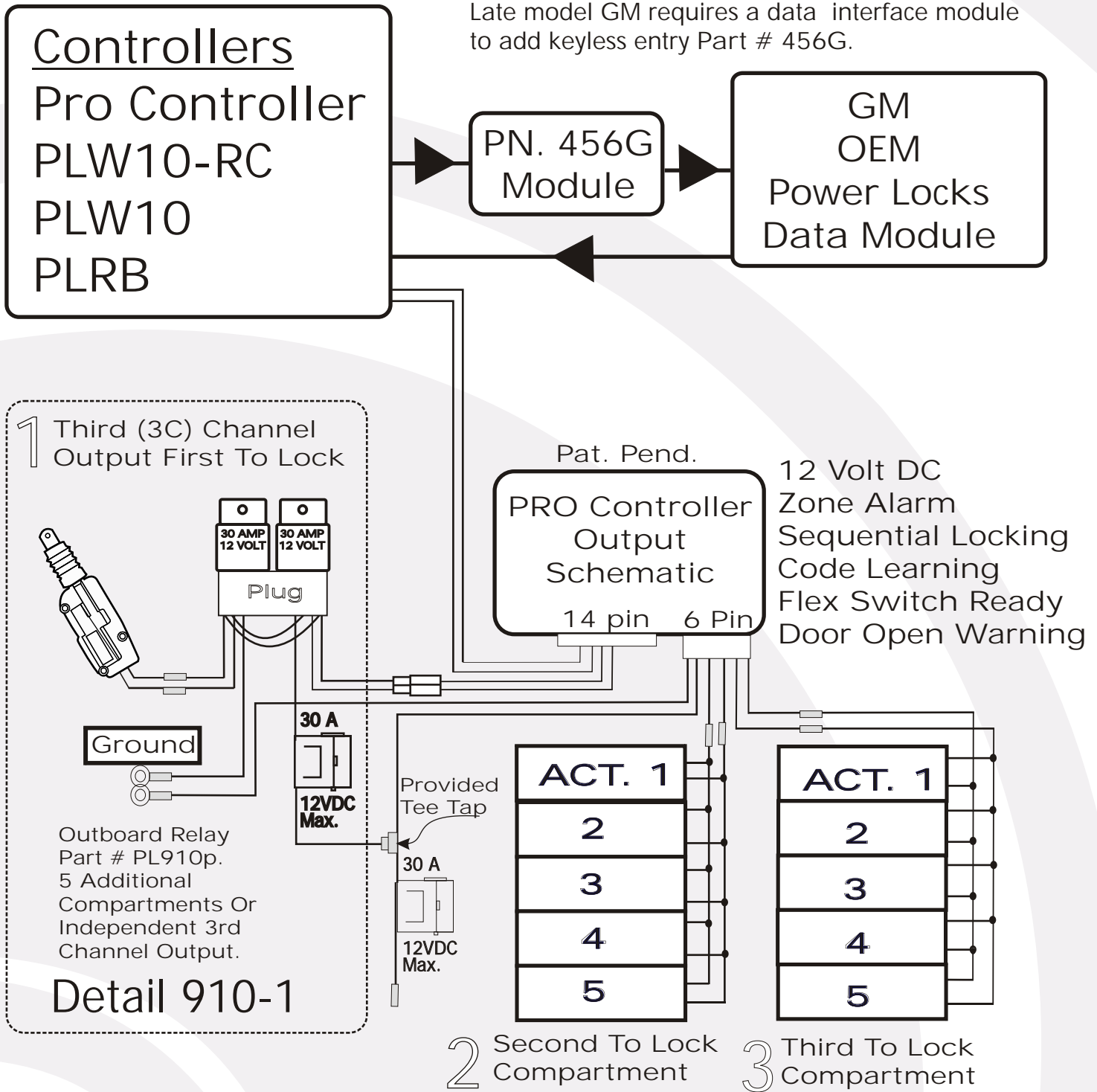

Cab triggered power locking can be done on all vehicles. GM requires OEM actuator input wires be intersected.